

ML09750 INSTALLATION/OPERATION INSTRUCTIONS

ML09750 Laser Line Projector - **GreenLine** 1MM INSTALLATION/OPERATION INSTRUCTIONS

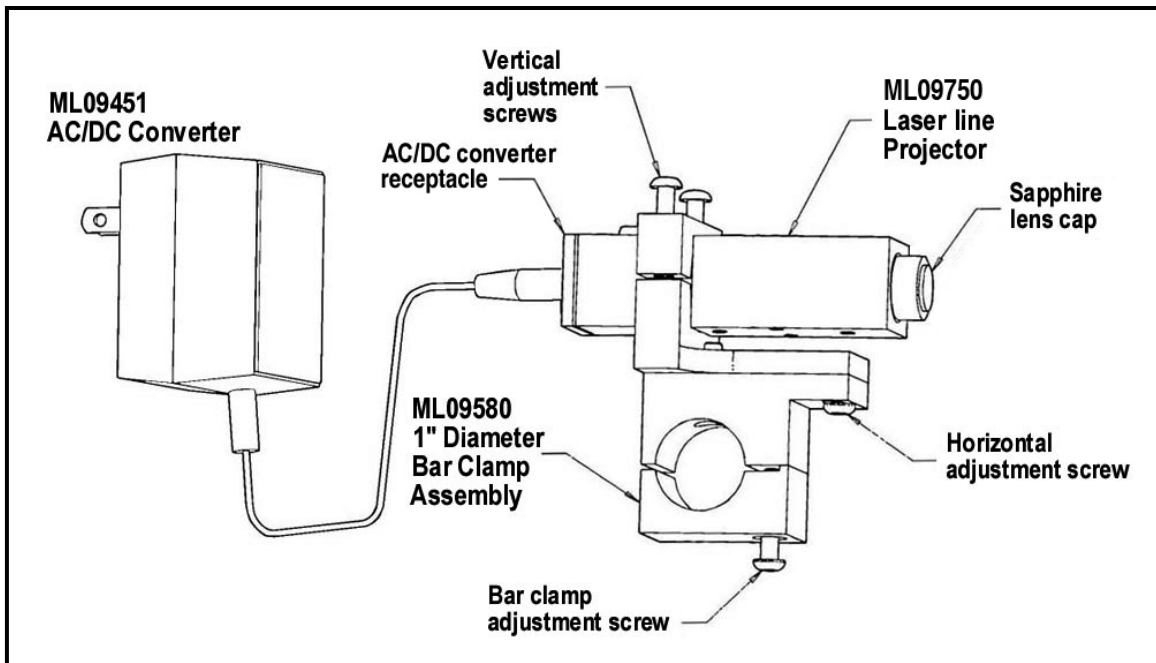

ASSEMBLY

ASSEMBLY OF ML09750 LASER LINE PROJECTOR WITH ML09580 1" BAR CLAMP ASSEMBLY

1. Remove the two vertical adjustment screws holding the two-piece bar clamp assembly together.
2. Place the grooved portion of the laser housing into the bottom piece of laser clamp.
3. Replace the top piece of the laser clamp with the two vertical adjustment screws and tighten.

INSTALLATION

INSTALLATION OF ML09750 LASER LINE PROJECTOR WITH ML09580 1" BAR CLAMP ASSEMBLY

1. Remove the lower half of the 1" diameter bar clamp assembly (ML09580) by removing the bar clamp adjustment screw.
2. Locate the positioner at a point on the bar known to be precisely in line with alignment points on the target.
3. Replace the lower half of the 1" diameter bar clamp assembly refitting the bar clamp adjustment screw.
4. Tighten the bar clamp adjustment screw just enough for the laser and positioner to fit snugly on the mounting bar, while still allowing for rotation of the laser/positioner on the mounting bar.
5. Power up the laser using the ML09451 AC/DC converter unit. (See Connecting Instructions below.)
6. Adjust the approximate vertical location of the line by rotating the laser/positioner on the mounting bar, and then tighten the bar clamp adjustment screw securely to lock down the laser/positioner on the mounting bar.

CONNECTING THE ML09750 LASER LINE PROJECTOR TO THE POWER SUPPLY

The Everhard ML09750 laser line projector requires a ML09451 120VAC / 7.5VDC 1.0A 7.5W regulated AC/DC converter or equivalent. To turn on the power to the projector, plug the jack from the AC/DC converter into the projector's AC/DC converter receptacle, and plug the AC/DC converter into a 120VAC outlet. The projector will produce a green beam, and the green pilot light will be on. If you have any technical problems regarding the projector, contact our sales department at (330) 453-7786.

WARNING: Failure to install and operate the projector with the ML09451 AC/DC converter, or equivalent, will void the warranty for the projector.

ML09750 Laser Line Projector - **GreenLine** 1MM

INSTALLATION/OPERATION INSTRUCTIONS

(continued)

OPERATION

1. The ML09750 laser line projector should be ordered with the ML09451 AC/DC converter (sold separately) and the ML09580 1" diameter bar clamp assembly (sold separately).
2. The ML09750 laser line projector is turned on when the jack from the ML09451 AC/DC converter is plugged into the projector's AC/DC converter receptacle, and the AC/DC converter is plugged into a 120VAC outlet. The projector will produce a green beam and the green pilot light will be on.
3. If the projector does not produce a beam, check to ensure the jack is properly inserted into the AC/DC converter receptacle.

PRECISE ADJUSTMENT OF ML09750 LASER LINE PROJECTOR WITH ML09580 1" BAR CLAMP ASSEMBLY

Adjustment of the ML09750 laser line projector is performed in two steps:

1. **Vertical adjustment of the laser line.**
2. **Horizontal (side-to-side) adjustment of the laser line.**

1. **Vertical Adjustment of the Laser Line on the Work Surface**

Tools required: 1/8" hex wrench, 1" open-end wrench.

A.) Loosen the two **vertical adjustment screws** with a 1/8" hex wrench just enough to be able to adjust the vertical angle (plane). **Laser should still fit very snugly in the two-piece laser clamp assembly.**

B.) Using a 1" open-end wrench on the laser housing, adjust the vertical angle (plane) of the laser line so it is an equal distance to the right or left of the target points. Once the laser line has been adjusted close to vertical on one side (right or left) of the target points, you are ready to adjust the horizontal angle (plane).

2. **Horizontal adjustment of Line**

Tools required: 1/8" hex wrench.

A.) MINOR Horizontal (side-to-side) Adjustment of the Laser Line on the Work Surface

The laser line can be moved left/right across the work surface by loosening the **horizontal adjustment screw**. This adjustment screw is for minor left/right adjustments. First, loosen the **horizontal adjustment screw** using a 1/8" hex wrench (provided). The projector can now be pivoted from side to side. Retighten the **horizontal adjustment screw** when the required angle has been achieved.

B.) MAJOR Horizontal (side-to-side) Adjustment of the Laser Line on the Work Surface

The laser line can be moved across the work surface for large left/right adjustments by loosening the **bar clamp adjustment screw** on the lower half of the 1" **diameter bar clamp assembly** (ML09580 — see diagram). To loosen the **bar clamp adjustment screw** use a 1/8" hex wrench (provided). The projector can now slide from side to side. Retighten the **bar clamp adjustment screw** when the required position has been achieved.

WARRANTY

The Everhard ML09750 laser line projector is warranted free from defects in material and workmanship for a period of TWO YEARS FROM THE DATE OF PURCHASE. Everhard Products, Inc. will repair or replace any laser line projector found to be defective under normal operating use during the course of the two year period. This warranty does not apply to laser line projectors that have been subject to modification, misuse, neglect, accident, improper use, power surges or spikes, improper maintenance, or repair by others not associated with Everhard Products, Inc.

WARNING: FAILURE TO INSTALL AND OPERATE THE PROJECTOR WITH THE ML09451 AC/DC CONVERTER, OR EQUIVALENT, WILL VOID THE WARRANTY FOR THE PROJECTOR. IN ADDITION, ANY UNAUTHORIZED DISASSEMBLY WILL VOID THIS WARRANTY AND MAY CAUSE IRREPARABLE DAMAGE TO THE PROJECTOR.